

Cooling High Power LEDs

Light-emitting diodes (LEDs) have long been used in instruments and computers as visual indicators for signal integrity and operations status. LEDs are ideal choices due to their high reliability, low power use and little to no maintenance needs. More recent market interest in LEDs is in their use, not only as indicators, but also as lighting devices. However, as illumination becomes the focus, the power consumption of LEDs has risen dramatically. Device heat fluxes are rivalling those of CPUs and other semiconductor packages. As a result, thermal management of LEDs has taken center stage for successful implementation.

It is important to remember that an LED is not a high temperature, filament-type lighting device. While a single LED is a cold and efficient light source, high-power LED applications, including arrays of LEDs, need thermal management similar to other semiconductor devices. High temperatures not only degrade an LED's lifetime, but also result in lower or non-uniform light output, which can significantly affect their application.

Most LEDs are designed in SMT (surface mount technology) or COB (chip-on-board) packages. In the new 1~8W range of surface mount power LED packages, the heat flux at the device's thermal interface can range from 5 to 20 W/cm². These AlInGaP and InGaN semiconductors have physical properties and limits similar to other transistors or ASICs (application specific integrated circuit). While the heat of filament lights can be removed by infrared radiation, LEDs rely on conductive heat transfer for effective cooling.

As higher powers are dissipated from LED leads and central thermal slugs, boards have changed to move this heat appropriately. Standard FR-4 technology boards can still be used for LEDs with up to 0.5 W of dissipation, but

metallic substrates are required for higher levels. A metal core printed circuit board (MCPCB), also known as an insulated metal substrate (IMS) board, is often used underneath 1W and larger devices. These boards typically have a 1.6 mm (1/16 inch) base layer of aluminum with a dielectric layer attached. Copper traces and solder masks are added subsequently. The aluminum base allows the heat to move efficiently away from the LED to the system [1].

Thermally dissipating PCBs are not always adequate or suitable for LED applications. Other cooling design choices are available, and it can be challenging to select the most appropriate and cost effective solution for a given application. In this article, we show the required approach for the thermal management of LEDs. This method enables the designer to select the appropriate cooling solution based on the LED's junction temperature and not on the total power dissipation.

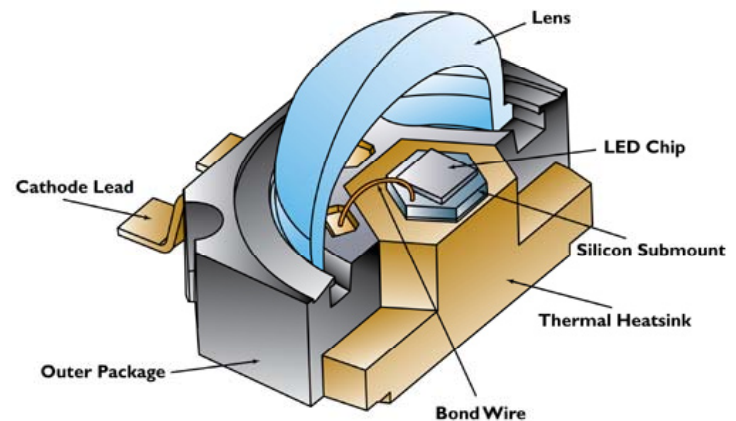

Figure 1. Luxeon K2 Power LED (courtesy of Lumileds).

INTRODUCING HEAT SINK TECHNOLOGY FOR LEDs FROM ADVANCED THERMAL SOLUTIONS

Create Something Amazing.



Advanced Thermal Solutions can solve the most difficult LED/Thermal challenges. ATS provides innovative and cost-effective thermal and mechanical packaging solutions for challenging LED lighting applications.

Our facilities include the most up-to-date software tools for analytical and computational modeling as well as, full thermal and fluids laboratories for experimental characterization of components, boards and systems.

ADVANCED THERMAL SOLUTIONS
89-27 Access Road
Norwood, MA 02026 USA
P:781.769.2800
ats@qats.com | www.qats.com



ATS ADVANCED
THERMAL
SOLUTIONS, INC.
Innovations in Thermal Management®

THERMAL FUNDAMENTALS

Two parameters play a pivotal role in the success of an LED. These are the cooling method and the optical lens. These factors affect the shape, size and construction of the luminaire that comprises the overall lighting unit. Because long life and fail safe operation are essential for any LED, the cooling process is uniquely critical. An LED's plastic body is not thermally conductive and the device does not radiate heat. The only effective cooling method is to conduct the heat away through the bottom of the device. Therefore, highly thermally conductive materials are commonly used to take the heat from the LED's back side (see Figure 1). Depending on power dissipation and light emission uniformity, the method of cooling can be passive (heat sink in natural convection) to active (fan-sinks) or can use liquid cooling.

With their basic, robust construction, LEDs can be used in environments ranging from ornamental to such critical illumination needs as automotive headlamps. Therefore, their cooling systems must be designed with the ambient temperature and the specific end use in mind. For example, a car's headlamp with an under-the-hood temperature of 85-100°C and power dissipation values of 42-90 W requires unique consideration for cooling and reliability. In other applications, to get the same light output

as an incandescent lamp, the LED lamp will often run on comparable power dissipation values. However, the LED device's maximum allowable junction temperature is limited to 120-135 °C (up to 185 °C in recent developments). If we compare these limits to an incandescent lamp, which allows filament operating temperatures of 1500-3000 °C, the thermal challenge for LEDs, especially in harsh environments, is the major obstacle to their successful implementation.

These thermal constraints typically need to be considered:

- $T_{\text{junction LED max}} < 120-185^{\circ}\text{C}$
- $T_{\text{junction LED lifetime}} < 100\sim 110^{\circ}\text{C}$
- $P_{\text{LED}} = 1-8 \text{ W}$
- Light output is strongly dependent on temperature

Cooling Options

The cooling options for LEDs range from simple natural convection in air to liquid cooling, where a cold plate and liquid loop form the required cooling system. Because most market applications for LEDs shy away from liquid

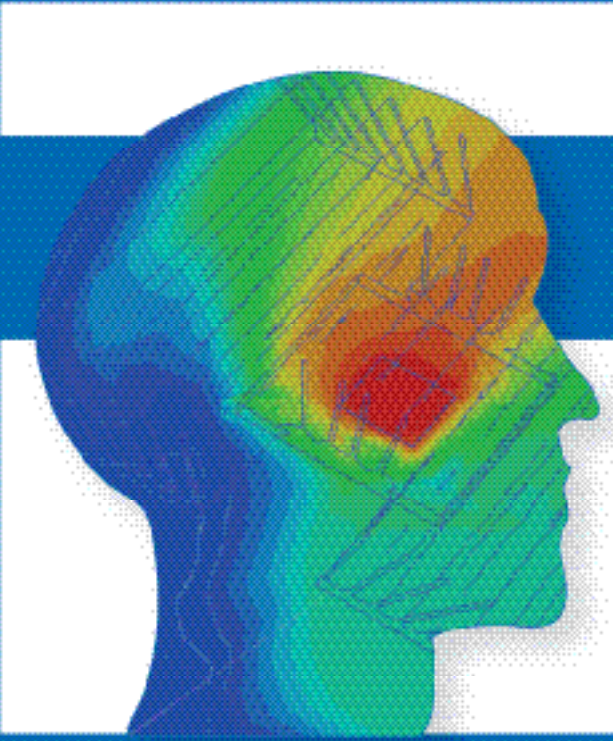

**THERMAL SOLUTIONS
ON YOUR MIND?**

ADVANCE YOUR THINKING.

Visit www.qats.com or call 781.769.2800 for more information or to schedule a consultation with our engineering or sales team.



ATS ADVANCED THERMAL SOLUTIONS, INC.
Innovations in Thermal Management[®]

cooling, the focus of this section will be on air cooling of LEDs.

Most LED lamps employ familiar heat sinking techniques. In some cases, the metal fixture of a luminaire can act as a heat sink, but the thermal requirements of its LEDs must be considered when designing the unit. Increasing power density, a higher demand for light output and space constraints are leading to more advanced cooling solutions. High-efficiency heat sinks, optimized for convection and radiation within a specific application, will become more and more important.

As with any semiconductor package, thermal resistance plays a significant role in the thermal management of LEDs. The highest thermal resistance in the heat transfer path is the junction-to-board thermal resistance (R_{j-b}) of the package [2]. Spreading resistance is also an important issue. Thermally enhanced spreader materials, such as metal core PCBs, cold plates and vapor chambers for very high heat flux applications are viable systems to reduce spreading resistance. [3]

Linear heat sinks are available specifically for LED strips, such as OSRAM SYLVANIA's DRAGONstick® linear LED strips, which are widely used in architectural lighting. For example, the maxiFLOW™ linear heat sink from Advanced Thermal Solutions has a patented spread fin array that maximizes surface area for more effective convection (air) cooling, particularly when air flow is limited, such as inside display cases.

Round heat sinks are available specifically for round LED boards, which are used to replace halogen light bulbs in applications such as spotlights and down lighting. A typical LED spotlight is shown in Figure 2 [5]. Here, a round QooLED® heat sink from Advanced Thermal Solutions is used for cooling three LEDs. The round heat sink has a special star-shaped profile fin design that maximizes surface area for more effective convection (air) and radiation cooling in the vertical mounting orientation, e.g., inside ceilings.

Active thermal management systems can be used for high-flux power LED applications. These include water cooling, two-phase cooling and fans. Although active cooling methods may not be energy-justifiable for LEDs, reasons for using them include ensuring lumen output, or

maintenance-free operation, or to meet specific wavelength requirements.

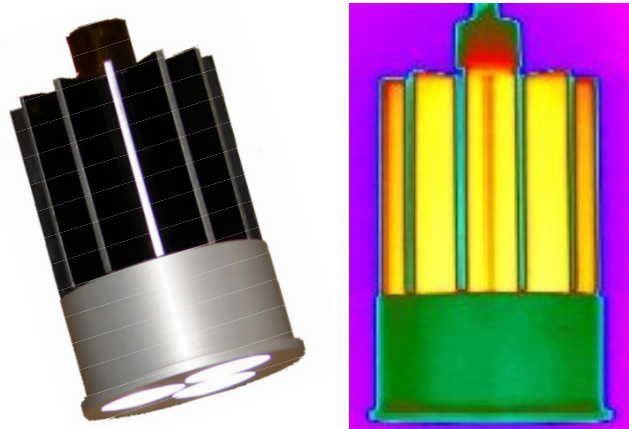

Figure 2. An LED-Based Spotlight with a Round, Finned Heat Sink, Visible and IR Views [5].

The LED Thermal Design and Cooling Solution Selection Process

The thermal design of any electronic component, including an LED, consists of three steps [4].

1. Analytical (Integral) Analysis
2. Computational (Numerical) Analysis
3. Experimental Analysis/Verification

Thermal Design - Analytical Analysis

Analytical analysis is used to develop a first-order solution. This approach identifies the problem areas (components and system layout) and ascertains the magnitude of the problem (device junction temperature and required level of cooling). Some analyses can be performed quickly to evaluate the scope of the problem – the so-called “what if” scenario.

Computational Analysis

Computational analyses are used to develop second-order solutions to verify results from Step 1. The problem must be well understood in order to develop a model that accurately represents the problem.

THERMAL FUNDAMENTALS

CFD (computational fluid dynamics) gives a total 3D picture of the problem. Both heat transfer and flow will be calculated. CFD is typically used to characterize the effect of spreading resistance within the PCB, the flow around the LED lamp and the thermal performance and optimization of a heat sink. Figure 3 shows some results from a CFD study of the LED-based spotlight discussed earlier.

Experimental Analysis/Verification

The final product must be tested experimentally, whether for compliance or effective operation. For an LED-based application, the junction temperature is measured by the forward voltage characteristic. The LED has to be calibrated first with a 10 mA constant current source. During the operational test, the current measurement source is on all the time, then, after stabilization, the operational current is switched off. After turning off the current, the drop in the forward voltage is measured. The thermal mass of the junction is small, which results in a fast cool-down time. This temperature change occurs in less than 1 msec, so the forward voltage has to be measured in microseconds after the event. More information can be found in Farkas, et al. [6].

The forward voltage together with the calibration curve will give the junction temperature under operational conditions. This junction temperature must be within specifications for both maximum and typical ambient conditions.

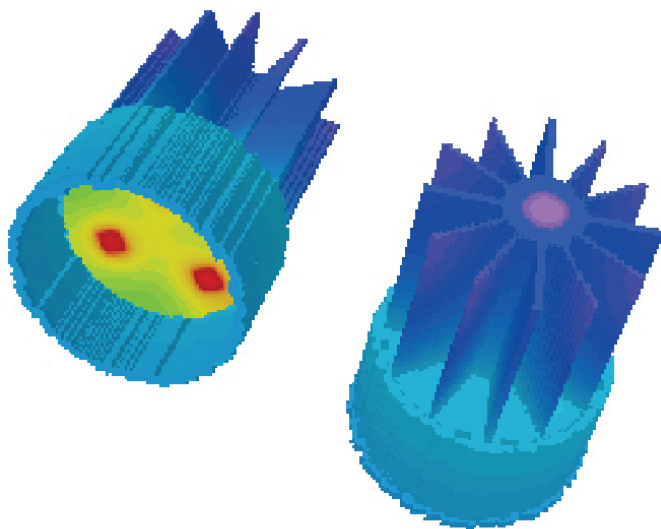

Figure 3. Results of a CFD Study on an LED-Based Spotlight

Conclusion

This article highlights the importance of thermal management to the successful use of LEDs. Selecting a cooling solution based on device (LED) junction temperature ensures that the most critical parameter, one that can adversely impact its reliability and performance, is identified and thermally managed. More importantly, developing a cooling solution based on an independent analysis approach, i.e., analytical, experimental and computational, provides a high degree of confidence for identifying the most effective cooling solution for high power LEDs.

References:

1. Petroski, J., *Thermal Challenges in LED Cooling*, *Electronics Cooling Magazine*, November 2006.
2. Siegal, B., *Measurement of Junction Temperature to Confirm Package Thermal Design*, *Laser Focus World*, November 2003.
3. Azar, K., *Cooling Electronics Theory and Application, a Short Course in Thermal Management of Electronic Systems*, Advanced Thermal Solutions, Inc.
4. Azar, K., Chapter 1, *Electronics Cooling and the Need for Experimentation, Thermal Measurements in Electronics Cooling*, CRC Press, New York, NY, 1997.
5. LED assembly provided by Universal Science Ltd.
6. Farkas, G., Haque, S., Wall, F., Martin, P., Poppe, A., van Voorst Vader, Q., and Bognar, G., *Electric and Thermal Transient Effects in High Power Optical Devices*, Twentieth IEEE SEMI-THERM Symposium, 2004.

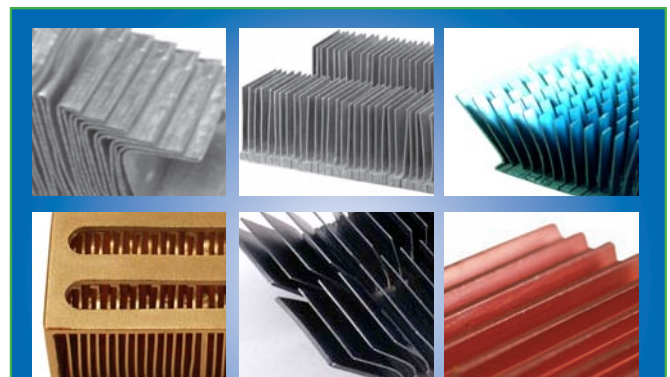

Advanced Thermal Solutions, Inc.

offers custom design solutions for every application.
Contact us at 781.769.2800 for details.

RESEARCH QUALITY LABORATORY TESTED OPEN LOOP WIND TUNNELS



CWT-100™

- Produces flow velocities from 0 to 6 m/s (1,200 ft/min)
- Test Section Dimensions (L x W x H): 34 cm x 29 cm x 8.5 cm (13.25" x 11.5" x 3.25")
- 12 Sensor ports

CWT-108™

- Produces flow velocities from 0 to 5 m/s (1000 ft/min)
- Test Section Dimensions (L x W x H): 61.0 cm x 61.0 cm x 20.32 cm (24" x 24" x 8")
- 18 sensor ports

CWT-PCB™

- Produces flow velocities from 0 to 10 m/s (2000 ft/min)
- Test Section Dimensions (L x W x H): 46 cm x 46 cm x 15 cm (18" x 18" x 6")
- 10 Sensor ports

Accessories

WTC-100

- Measures velocities at temperatures from 20°C to 65°C ($\pm 1^\circ\text{C}$)
- Capable of controlling velocities from up to 50 m/s (10,000 ft/min) depending on the fan tray
- Features a user friendly, labVIEW based, application software

Candlestick Sensor

- Flexible, robust, base-and-stem design allows continuous repositioning and reading
- Measures temperature and velocity. Narrow and low profile minimizes the disturbance flow
- Temperature range from -15°C to 120°C ($\pm 1^\circ\text{C}$)



New Star Heat Sinks Cool High Heat Flux LEDs



Advanced Thermal Solutions, Inc. (ATS) has introduced the Star™ Series of heat sinks designed specifically for cooling higher power, surface mount power LED packages. High temperatures not only degrade an LED's lifetime, but also result in lower light or non-uniform output – effects that can significantly affect their application. The 32 new Star heat sinks provide enhanced conductive heat transfer for effective LED cooling without fans or blowers. Cooling performance in the series ($\Delta T_{hs-ambient}$) reaches more than 60 K at up to 16 Watts of power dissipation.

All Star heat sinks are made from light weight aluminum in a cylindrical shape that fits common LED lamp applications. Their cooling fins are arrayed in a round, star-like cross section that optimizes thermal performance through radiative cooling to the local air flow. A flat surface at one end of the heat sink provides a base for direct mounting of LEDs. Integral threads on the base perimeter allow attachment of brackets and other hardware. All standard sizes are available with an inner thread for convenient attachment of LED lens mounts.

ATS' Star heat sinks are available in 25, 45, 50 and 75 mm (0.98, 1.77, 1.96 and 2.95 inches) lengths with a standard diameter of 45 mm (1.77 inches). Each heat sink features a black anodized finish that provides corrosion resistance, electrical insulation, and improved thermal performance. All heat sinks within the series are RoHS compliant.

Unit pricing for Star Series LED cooling solutions start at less than \$8.00 in production quantities. For more information, visit the Advanced Thermal Solutions website, www.qats.com, or call 1-781-769-2800.

EVENTS



THERMAL SOLUTIONS

January 21-24, 2008
Sarasota, FL

SMTA - PAN PACIFIC MICROELECTRONICS SYMPOSIUM

January 22-24, 2008
Kauai, Hawaii

SEMI-THERM

March 16-20, 2008
San Jose, CA

IMAPS - INTERNATIONAL CONFERENCE AND EXHIBITION ON DEVICE PACKAGING

March 17-20, 2008
Scottsdale/Fountain Hills, AZ

IPC PRINTED CIRCUITS EXPO, APEX AND THE DESIGNERS SUMMIT

April 1-3, 2008
Las Vegas, NV

EUROPEAN THERMAL - SCIENCES CONFERENCE

May 18-22, 2008
Eindhoven, the Netherlands

ELECTRONIC COMPONENTS AND TECHNOLOGY CONFERENCE

May 27-30, 2008
Lake Buena Vista, FL

MICROTCA SUMMIT

May 28-30, 2008
Lake Buena Vista, FL

SENSORS EXPO AND CONFERENCE

June 9-11, 2008
Rosemont, IL

WHO WE ARE



Advanced Thermal Solutions is a leading engineering and manufacturing company supplying complete thermal and mechanical packaging solutions from analysis and testing to final production. ATS provides a wide range of air and liquid cooling solutions, laboratory-quality thermal instrumentation, along with thermal design consulting services and training. Each article within Qpedia is meticulously researched and written by ATS' engineering staff and contributing partners. For more information about Advanced Thermal Solutions, Inc., please visit www.qats.com or call 781-769-2800.

ADVANCED THERMAL SOLUTIONS, INC.

United States

89-27 Access Road, Norwood, MA 02062
T: 781.769.2800 | F: 781.769.9979 | www.qats.com

Europe

De Nieuwe Vaart 50 | 1401 GS Bussum | The Netherlands
T: +31 (0) 3569 84715 | F: +31 (0) 3569 21294
www.qats-europe.com



ATS ADVANCED
THERMAL
SOLUTIONS, INC.
Innovations in Thermal Management®



Getting your Company's Message out to Over 21,000 Engineers & Industry Professionals has Never Been Easier.

Advertise in Qpedia Today!

Qpedia was launched in 2007 as a technology eMagazine focused on the thermal management of electronics. It is designed as a resource to help the engineering community solve the most challenging thermal problems.

The newsletter is published monthly and distributed at no charge to over 21,000 engineers worldwide. Qpedia is also available online or for download at www.qats.com/qpedia.

Qpedia's editorial team includes ATS' President & CEO Kaveh Azar Ph.D., and Bahman Tavassoli Ph.D., the company's chief technologist. Both Azar and Tavassoli are internationally recognized experts in the thermal management of electronics.

For more information on how you can generate awareness about your company or products, contact Ray Santos at 782.769.2800.