



## Overview

USB-C Universal Orientation Cable (UOC) is a custom coaxial construction USB-C male to USB-C male cable for use with Acroname's programmable [USB-C-Switch](#) and [USB-C Hub](#). The UOC provides an orientation-agnostic USB-C connection, required for cable flip automation with the USB-C-Switch or USB-C Hub. By acting as a transparent USB-C port extension, the UOC enables validation and manufacturing testing of USB-C devices including both USB-C cable orientations without needing to manually rotating cable connections. The cable is marked with Acroname logos on each cable end that correlates to the cable's A side to aid in visual identification in application setups. The C67 cable is specialized for applications with a device that shorts the A and B side USB 2.0 D+/D- signals together (cameras, flash drives, development boards).

Typical applications include:

- Manufacturing testing of USB Type-C ports
- USB device validation and development
- Cable orientation “flip” testing (requires USB-C-Switch or USB-C Hub)

## Features

- USB-C male to USB-C male
- Coaxial construction on super speed wires
- Acroname logo marking on A side of cable connector
- Supports USB 4.0 / 40Gbps link speeds
- Supports USB PD modes up to 48V / 5A
- USB-C Orientation Agnostic
- 0.7 meters in length
- No E-mark or SOP functionality on CC1 or CC2 pins

### Absolute Maximum Ratings

Stresses beyond those listed under ABSOLUTE MAXIMUM RATINGS can cause permanent damage to the device. These are stress ratings only and functional operation of the device at these or any other conditions beyond those indicated under RECOMMENDED OPERATING CONDITIONS is not implied. Exposure to absolute-maximum rated conditions for extended periods affects device reliability and may permanently damage the device.

Parameter	Minimum	Maximum	Units
Voltage on V <sub>BUS</sub> pins A4, A9, B4, B9	-	60.0	V
Current on V <sub>BUS</sub> pins A4, A9, B4, B9	-	5.0	A
Current on CC1, CC2 pins A5, B5	-	1.25	A
Current on SSTXp1, SSTXn1, SSRXp1, SSRXn1, SSTXp2, SSTXn2, SSRXp2, SSRXn2, Dp, Dn, SBU1, SBU2	-	0.25	A

Table 1: Absolute Maximum Ratings

### Handling Ratings

Parameter	Conditions/Notes	Minimum	Typical	Maximum	Units
Ambient operating temperature, T <sub>A</sub>	Non-Condensing	0.0	25.0	50.0	°C
Storage temperature, T <sub>STG</sub>		-10.0	-	85.0	°C

Table 2: Handling Ratings

### Recommended Operating Ratings

Values presented apply to the full operating temperature range.

Parameter	Conditions/Notes	Minimum	Typical	Maximum	Units
Voltage on V <sub>BUS</sub> pin		0.0	-	48.0	V

Table 3: Recommended Operating Ratings

### Typical Performance Characteristics

Values presented apply to the full operating temperature range.

Parameter	Conditions/Notes	Minimum	Typical	Maximum	Units
DC Resistance of V <sub>BUS</sub>	A4, B4, A9, B9	10.8	14.9	15.9	mΩ
SSTXp1, SSTXn1, SSRXp1, SSRXn1, SSTXp2, SSTXn2, SSRXp2, SSRXn2, Dp1, Dn1, Dp2, Dn2		331	334	338	mΩ
SBU1, SBU2, CC1, CC2		294	298	304	mΩ

Table 4: Typical Performance Characteristics

### Typical Applications

The UOC should only be used in conjunction with the USB-C-Switch. It will not function without a standard USB-C cable somewhere in the system. In most applications involving only one USB-C-Switch, there will be only one UOC in any connection path. Generally, the UOC should be connected to the device under test (DUT), where the DUT is the device which needs to have both connector orientation tested or verified. The following block diagrams show two simple examples utilizing the UOC and the USB-C-Switch to test cable flip on the DUT port or ports.

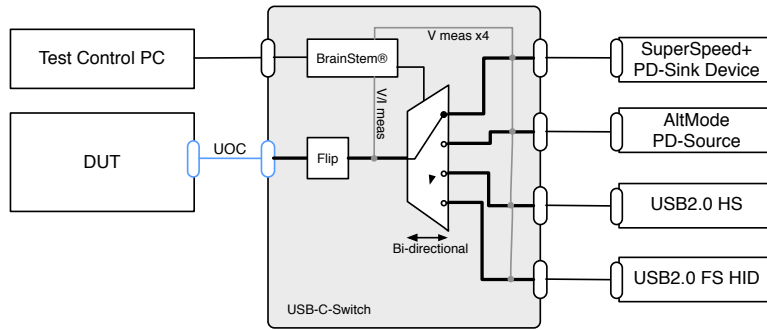

Figure 1: Application example using the UOC and USB-C-Switch to emulate cable flips on one DUT port and connecting multiple types of downstream devices.

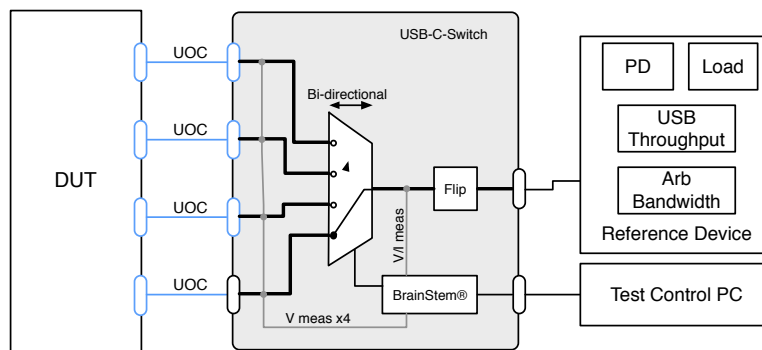

Figure 2: Application example using the UOC and USB-C-Switch to emulate cable flips on multiple DUT ports and connecting a reference downstream device.

## Typical Full Featured USB Type-C Interface Assembly Wiring

Plug Front View ①	A12	A11	A10	A9	A8	A7	A6	A5	A4	A3	A2	A1
	GND	RX2+	RX2-	VBUS	SBU1	D-	D+	CC	VBUS	TX1-	TX1+	GND
	GND	TX2+	TX2-	VBUS	VCONN	NC	NC	SBU2	VBUS	RX1-	RX1+	GND
	B1	B2	B3	B4	B5	B6	B7	B8	B9	B10	B11	B12

Figure 1: Typical USB-C Male Receptacle Assignment

**C67-USBC-UOC Assembly Wiring (Revision A)**

USB Type-C Plug #1 Pin	USB Type-C Plug #1 Signal Name	USB Type-C Plug #2 Pin	USB Type-C Plug #2 Signal Name
A1, B1, A12, B12	GND	A1, B1, A12, B12	GND
A4, B4, A9, B9	VBUS	A4, B4, A9, B9	VBUS
A5	CC1	A5	CC1
B5	CC2	B5Error! Bookmark not defined.	CC2
A6	Dp1	A6	Dp1
A7	Dn1	A7	Dn1
B6	Not-Connected	B6	Not-Connected
B7	Not-Connected	B7	Not-Connected
A2	SSTXp1	B11	SSRXp1
A3	SSTXn1	B10	SSRXn1
B11	SSRXp1	A2	SSTXp1
B10	SSRXn1	A3	SSTXn1
B2	SSTXp2	A11	SSRXp2
B3	SSTXn2	A10	SSRXn2
A11	SSRXp2	B2	SSTXp2
A10	SSRXn2	B3	SSTXn2
A8	SBU1	B8	SBU2
B8	SBU2	A8	SBU1

**Performance Characteristics**

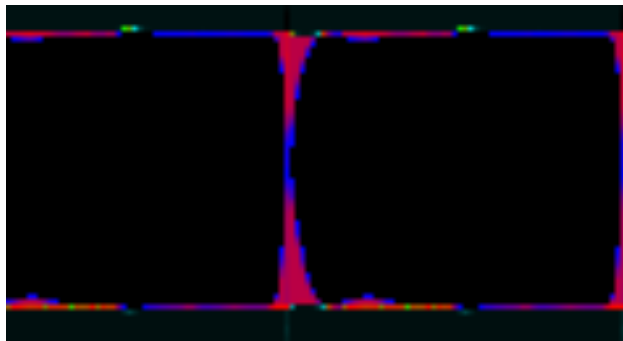

Figure 2: USB 2.0 Eye Diagram at 480 Mbps

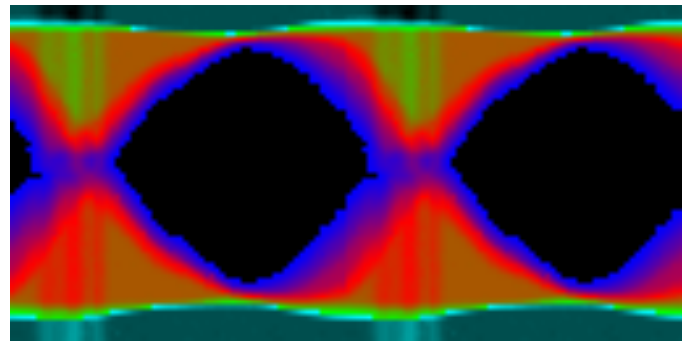

Figure 4: USB3 SSTX Eye Diagram at 12 Gbps

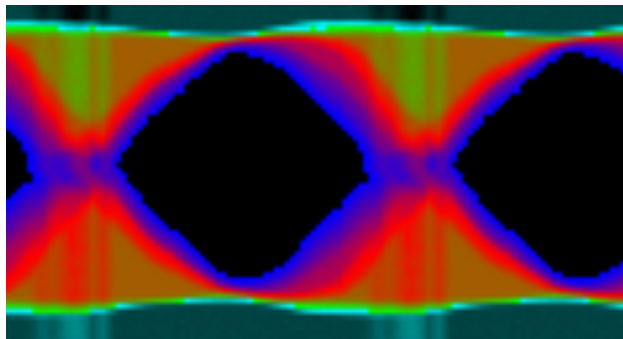

Figure 3: USB3 SSRX Eye Diagram at 12 Gbps

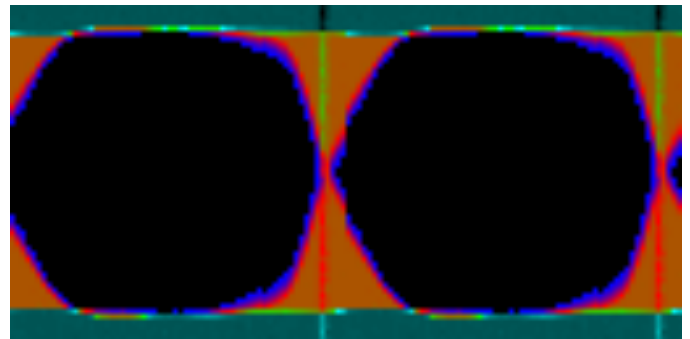
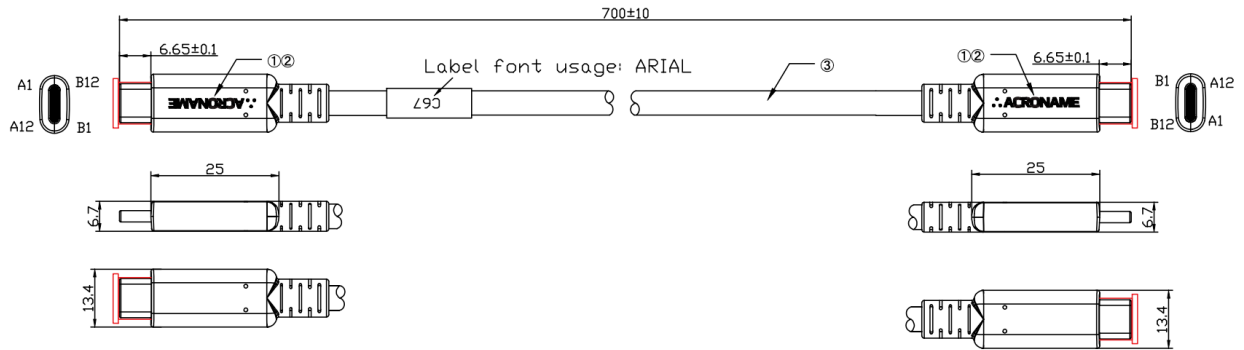

Figure 5: USB3 SSTX Eye Diagram at 5 Gbps

### Mechanical

Dimensions are shown in [mm].



## Product Support

Questions about the product operation or specifications are welcome through Acroname's contact portals. Software downloads, reference API and application examples are available online at:

<https://acroname.com/support>

Direct communication and additional technical support are available at:

<https://acroname.com/contact-us>

2741 Mapleton Avenue

Boulder, CO, USA 80304-3837

720-564-0373 (phone)

## Document Revision History

All major documentation changes will be marked with a dated revision code

Revision	Date	Engineer	Description
1.0	March 2024	GCF	Initial release