

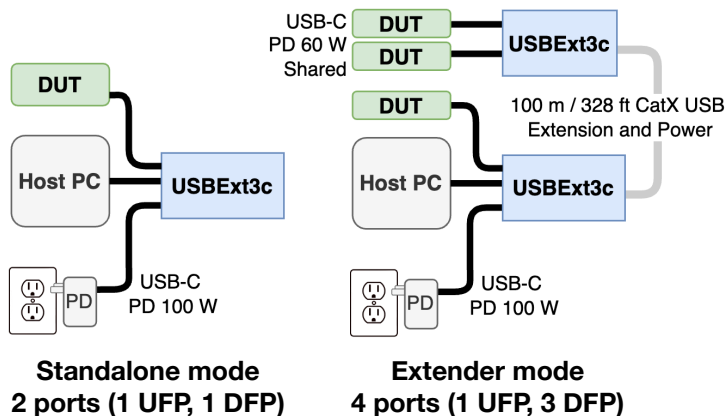

USBExt3c is a high-performance, managed industrial USB-C hub with Integrated **USB and power extension**. Ports provide up to 60 W USB-PD shared output per device when powered over Cat cable and 90 W when locally powered.

Identical USBExt3c devices can connect to each end of a category cable and interchangeably act as senders or receivers. **Any port on either unit can be dynamically configured as upstream facing (UFP) to connect to a host or downstream facing (DFP) to connect to devices.**



Local USB links of up to **10 Gbps** and a **5 Gbps** extension link over **100 m** of Cat 6A cable provide flexible connectivity with galvanic isolation for high bandwidth devices.

Fully software managed, USBExt3c provides extensive port monitoring and control options via the **HubTool GUI application** and **Brainstem API** for interactive and automated workflows.

Industrial Applications

Comprehensive USB-C port testing for the lab or factory

- **Full port control** — Verify and force USB link speeds, enable and disable ports to set enumeration order, independently control USB 2 and USB 3 lines. Set maximum connection speed to force specific data rates
- **Virtual “cable flip”** — Independently test USB functions on either side of the USB-C connector with optional Universal Orientation Cable (UOC)
- **Plot, log, and decode** — Plot V_{bus} voltage and current, log and decode PD negotiation and send arbitrary VDM PD messages (*)
- **Hot-Plug stress testing** — Automate cable connect/disconnects without physical interaction. Script plug-cycle stress testing

Camera Extension for Industrial Computer Vision: USB 3 and Power

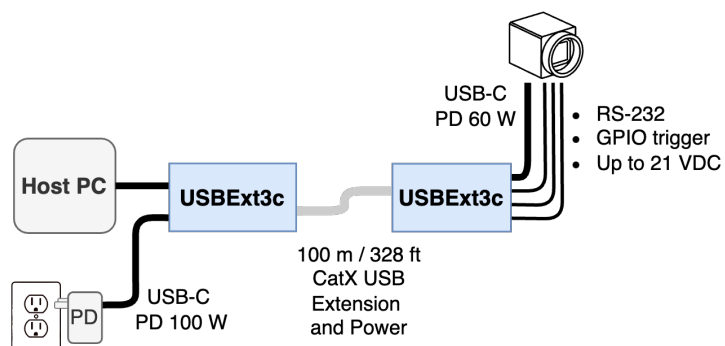

- Extend 4k USB 3 cameras to hard-to reach locations without available power
- Remote power for up to 60 W USB-PD or programmable 2.8 — 21 VDC connection for non-PD devices (adapter cable required)
- Frame synchronization and triggering over low latency digital I/O
- RS-232 pass-through extension for camera configuration and triggering

USB 2.0 and USB 3.1 Galvanic Isolation

- Remove ground loops and PC power supply-induced noise,
- Improve SNR of USB Digital Acquisition (DAQ) tools
- Maximize setup flexibility: safely extend test fixtures up to 100 M from the host PC

(*) Indicates optional firmware feature

USBExt3c

Industrial USB-C Hub with Extension and Power Delivery

Emulate any PD source up to 90 W

Test USB-powered devices against any charger they might encounter.

- Full independent control of V_{bus} and advertised PDOs to emulate out-of spec devices and over/under-voltage conditions (*)

Flexible Power

- Up to 100 W USB-PD power can be input to **any USB port on either device**
- **Power over Extension** — Power on one USBExt3c and the other unit will receive power over the Category cable. Ports on the non-powered side can provide up to 60 W USB-PD (shared).
- **Local Power** — Connect 100 W USB-PD supplies to both units to provide up to 90 W shared power per side.
- **Programmable DC power source*** — Available USB ports can provide up to 21 V DC to non-PD devices using an optional adapter cable.

Reliable Extension

The USBExt3c uses HDBaseT-USB3 technology based on Valens VS6320 to provide USB 3.1, 2.0, and legacy 1.0 extension over standard category cable. Cameras up to 4K and both Isochronous and bulk transfer modes are supported.

Robust Mounting Options

USBExt3c features M4 mounting threads on either side for rack shelf mounting via L-bracket feet or to DIN rail via adapter. All USB ports accept single-screw locking USB cables.

Extendable Capabilities

USBExt3c's capabilities can be expanded with optional add-on software features and hardware accessories.

Software Add-on Features

PD-Builder: Customize local port Power Data Objects (PDOs) to emulate various PD source capabilities. Includes *Power Rule Editor*

V_{bus} Validation: Override V_{bus} voltage set points and current limits to test a sink's response to incorrect voltages. Enables each port to act as a **controllable DC power supply** with independent voltage and current limits (2.8 – 21 V, 0 – 5 A)

PD Logger: Log PD communications across all USBExt3c ports. Provides message decoding, including power negotiation, alternate mode negotiation, and VDM data display

Serial Control: Enable control of the USBExt3c via RS-232 serial interface

HubTool Application

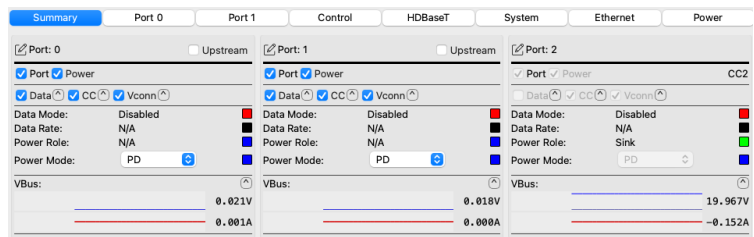

The HubTool interface presents a unified dashboard to interactively control and view the state of USBExt3c. Free download for Windows, MacOS and Linux distributions.

BrainStem API

Control and automate all USBExt3c functions with the BrainStem API (C, C++, Python, LabView, .NET). Integrate into your test scripts or custom applications.

Ports (per USBExt3c)	2 full-featured USB-C Ports, 1 dedicated USB-C control / power port
	HDBaseT-USB3 (Cat X) extension
	Ethernet Control port, RS-232, GPIO
Max Extension	100 m / 325 ft with Cat 6A U/FTP, S/FTP
Max USB 3.2 Data Rate	10 Gbps local
	5 Gbps over extension
USB-PD Power Output	60 W if powered over extension
	90 W if locally powered
USB-PD Power Input	100 W into any port

(*) Indicates optional firmware feature